

Practical case: Standby mode indicator

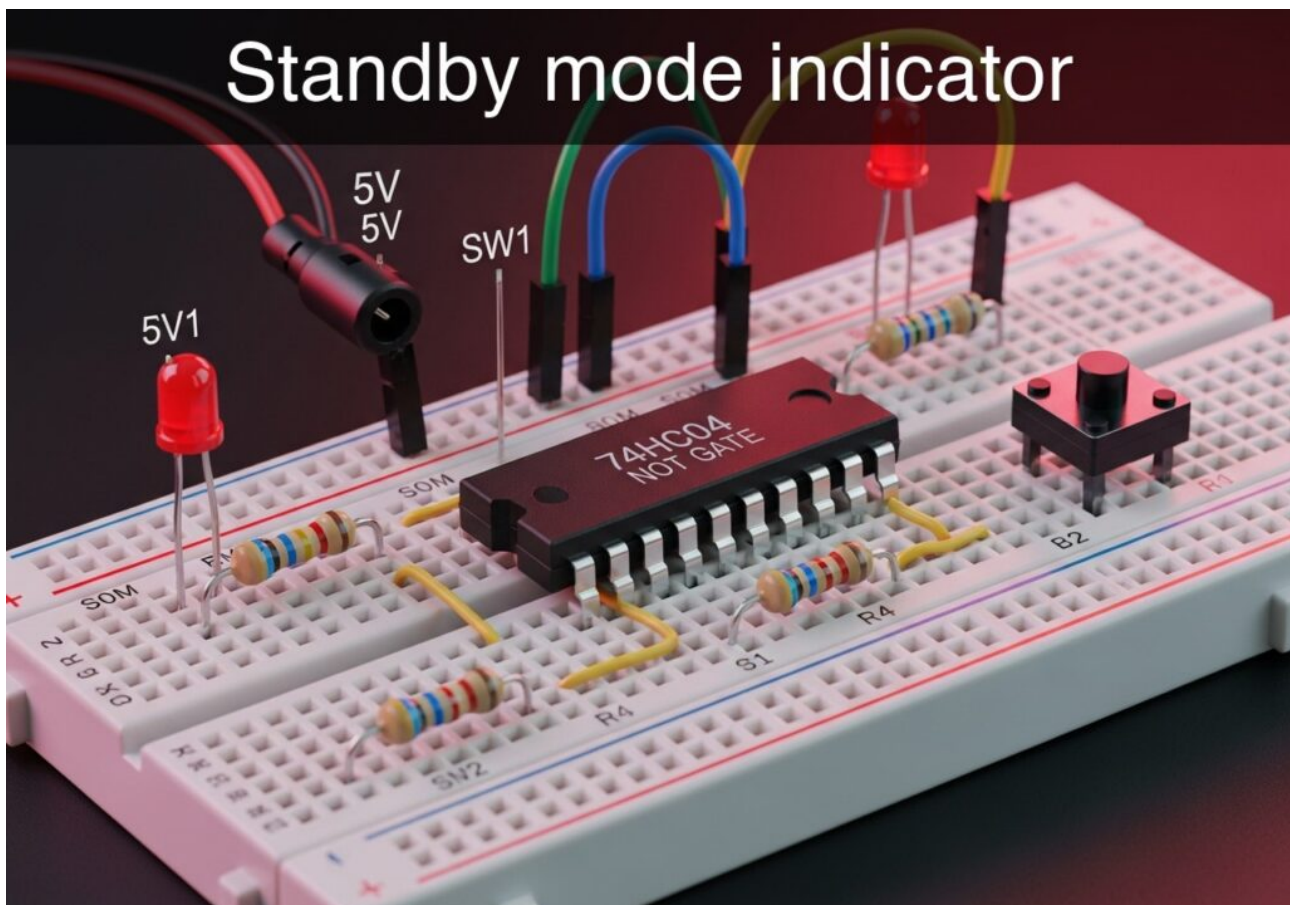

Level: Basic - Understand logical inversion using a NOT gate to activate a standby LED when the main system turns off.

Objective and use case

You will...

Practical case: DC motor control with a transistor

DC motor control with a transistor

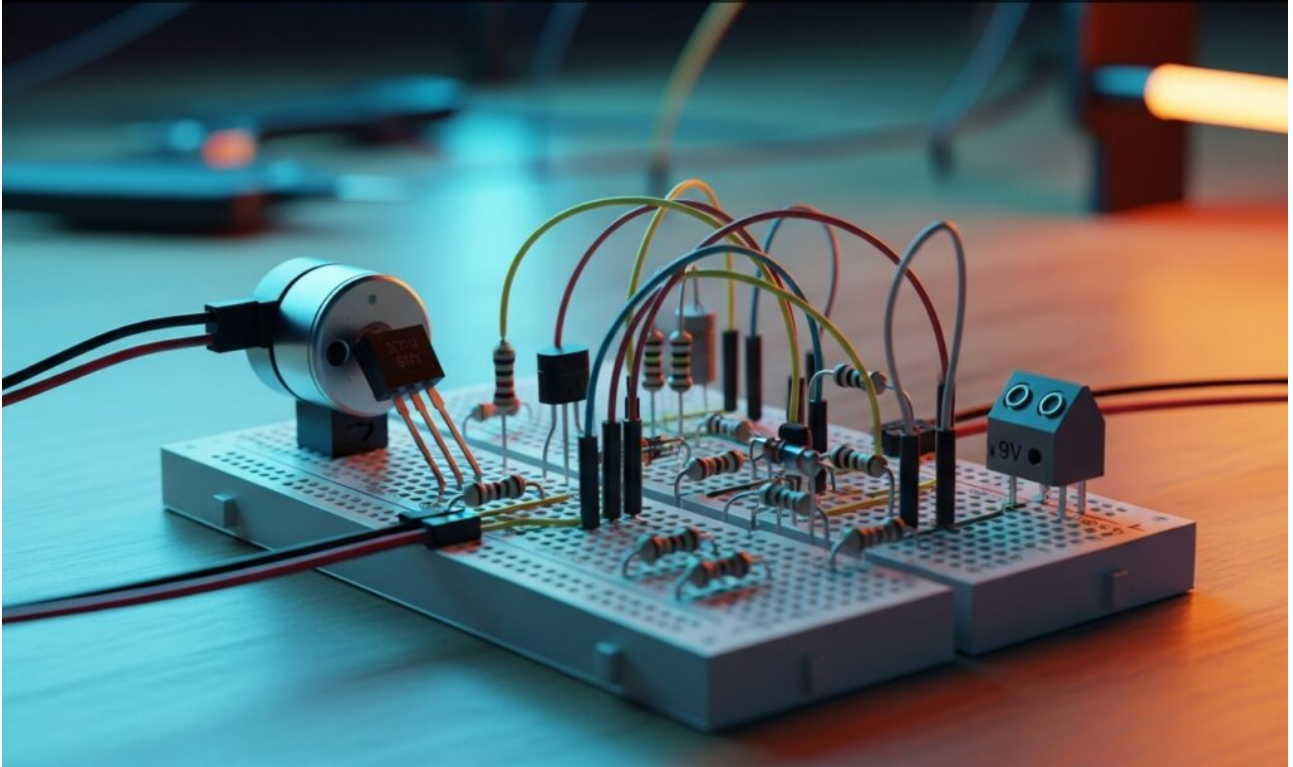

Level: Basic - Learn to use an NPN transistor as a switch to drive a DC motor, including the use of a flyback diode.

Objective and use case

In this...

Practical case: Frequency divider by 2, 4 and 8

Frequency divider by 2, 4 and 8

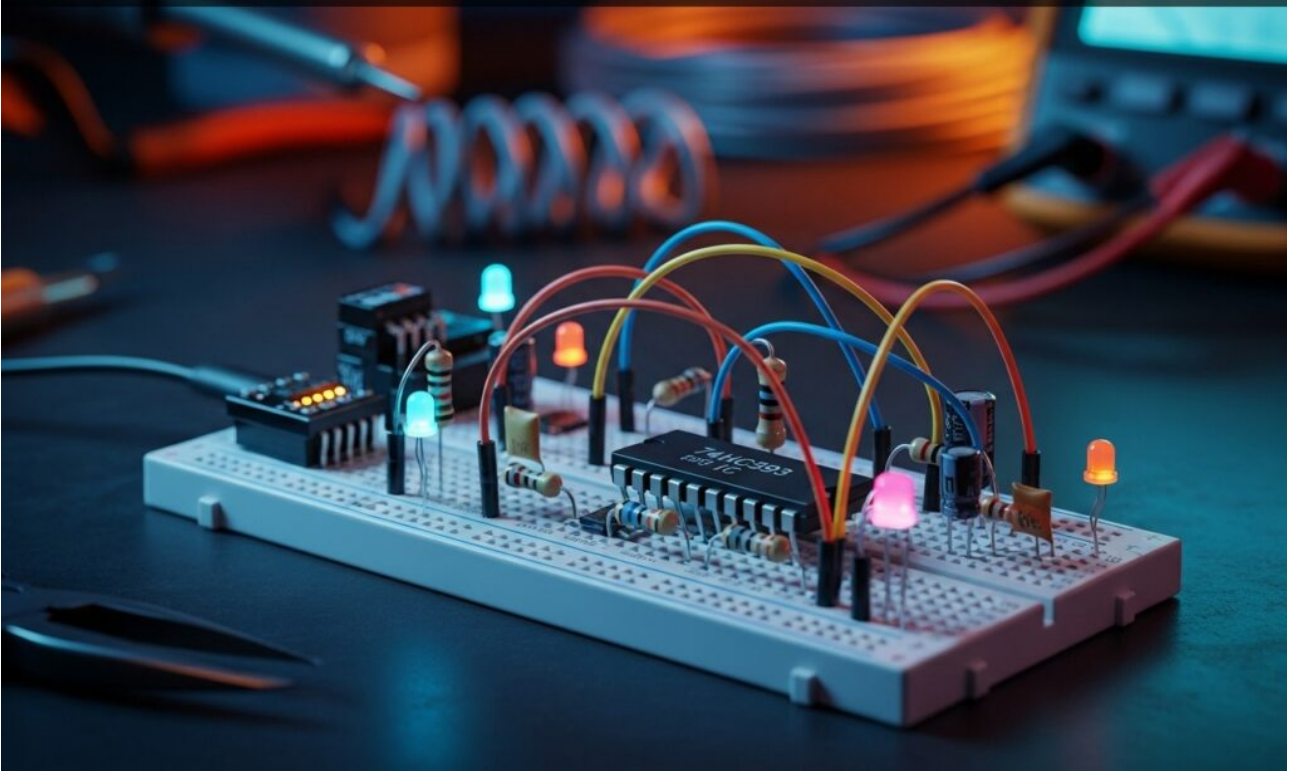

In this Digital Electronics lab, use a Binary counter to build a frequency divider. Verify square wave outputs at $f/2$, $f/4$, and $f/8$ relative to the clock.

Practical case: 4-bit up counter with LEDs

4-bit up counter with LEDs

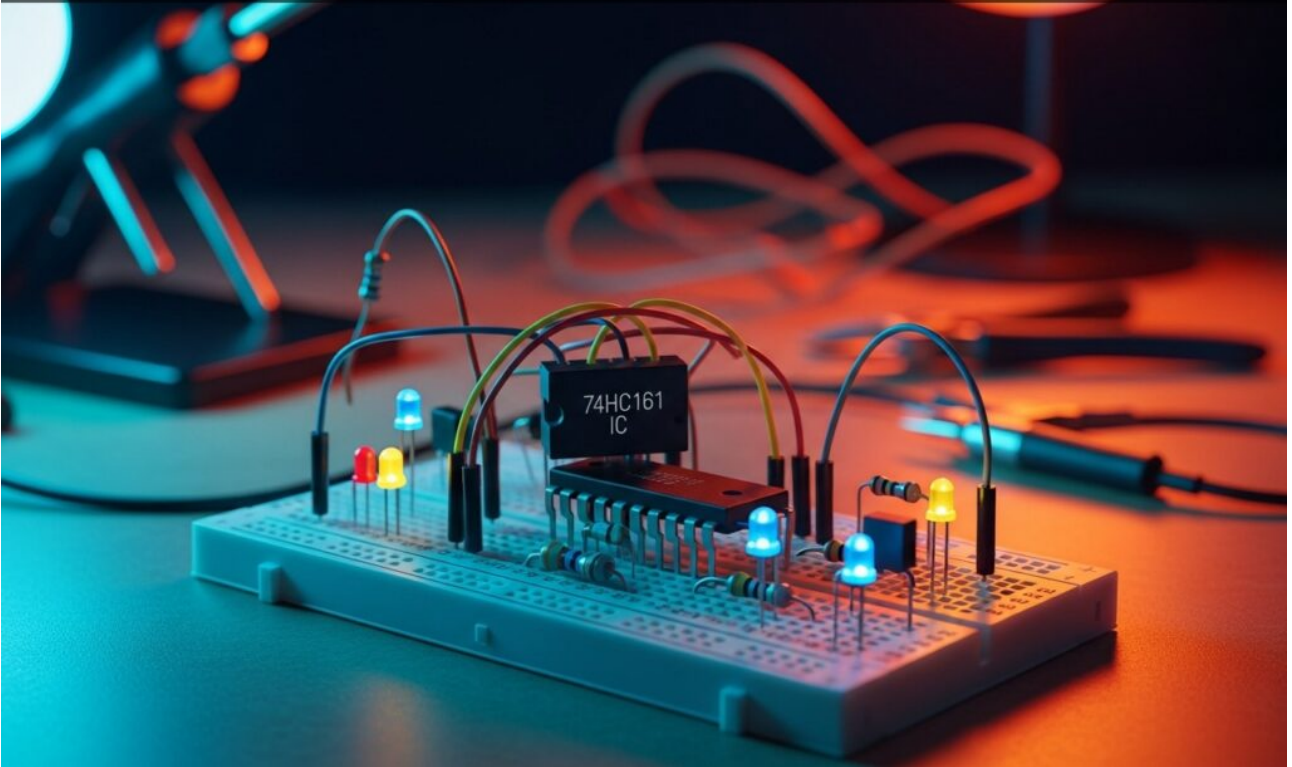

Build a practical Digital Electronics circuit with a Binary counter. Visualize the 0 to 15 sequence on LEDs and verify synchronous clock signals.

Practical case: Vault Lock with Delay and Power Drive

Vault Lock with Delay and Power Drive

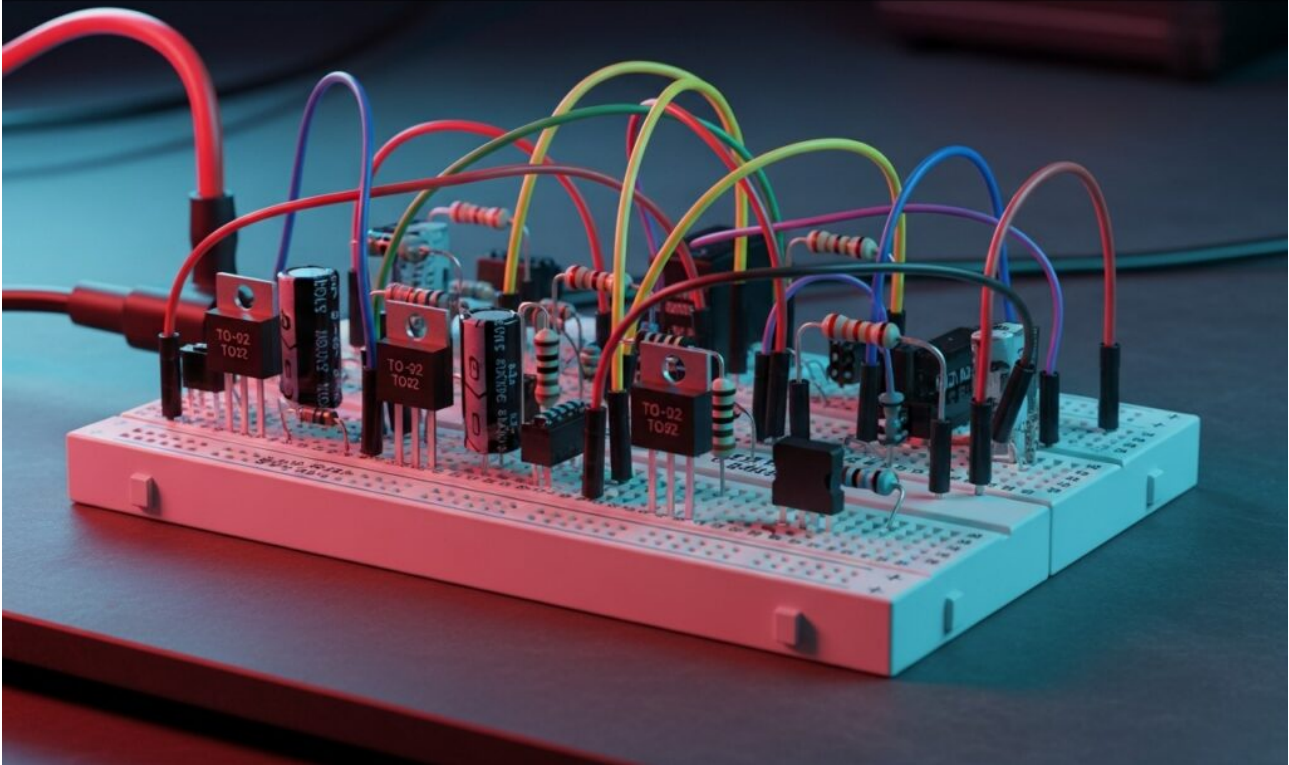

Master Analog Electronics by building a secure lock. Use a Transistor circuit to trigger a solenoid only when two keys turn, holding the signal for 5 seconds.

Practical case: The Undefined Logic Level Danger

The Undefined Logic Level Danger

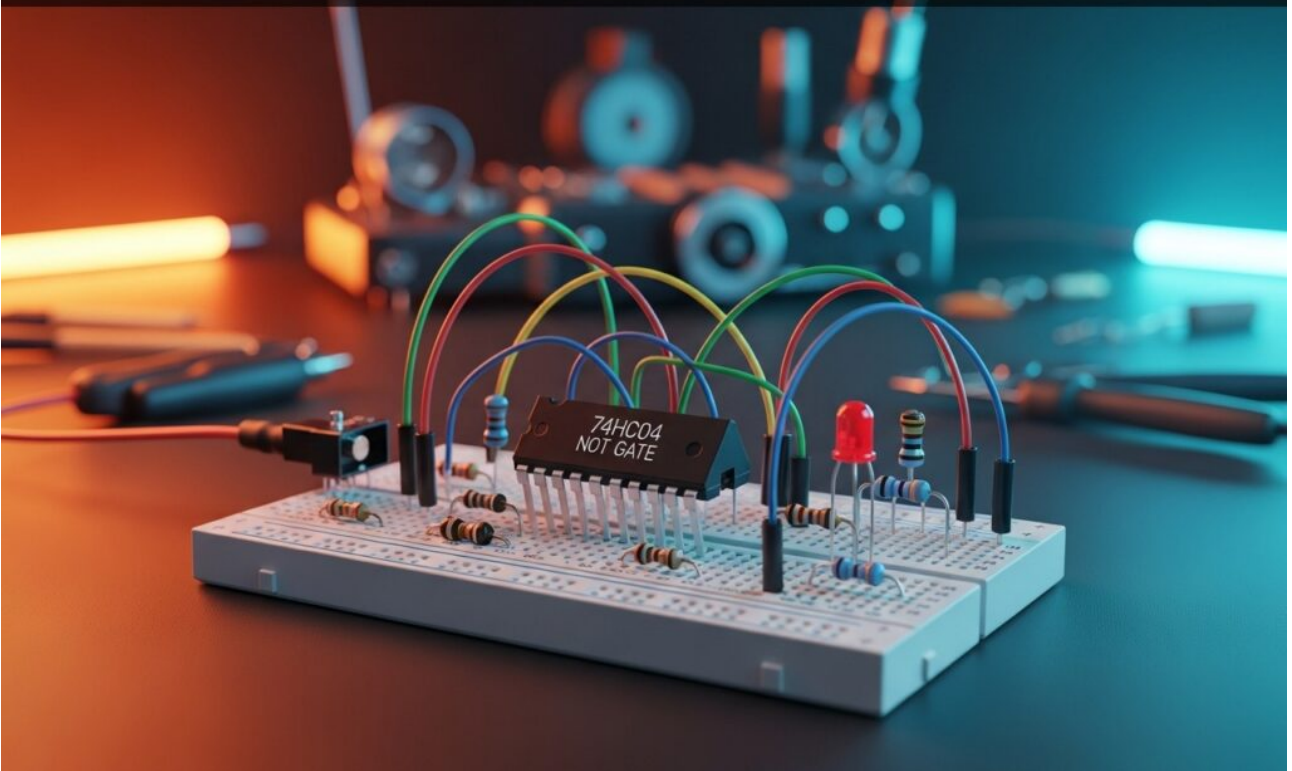

Master Analog Electronics by analyzing unstable logic states. Learn how internal Transistor behavior causes shoot-through current and flickering LED outputs.